

Data Sheet
INTAX® Tx F08

Edition 14. Juni 2022

**INTAX® linear motor axes with
integrated servo controller**

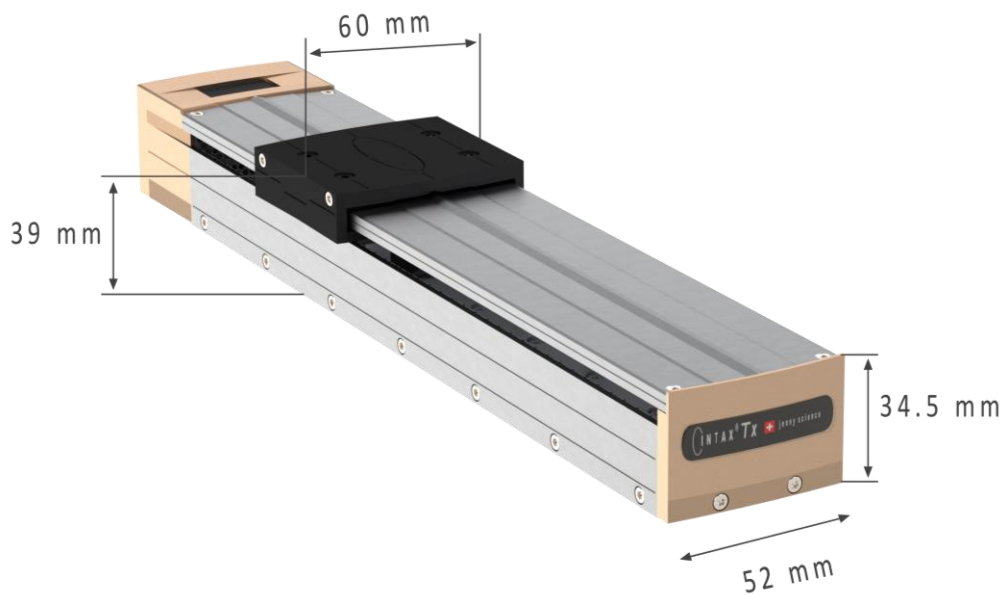

Highlights

Your PLC can be connected directly to the INTAX® axis using the industrial Ethernet bus.

You start the movement immediately, without any reference travel.

Save the external servo controller and the electric cabinet wiring.

Build your machines and apparatuses now more compact, lighter and in shorter development time.

General

Never before has a linear motor direct drive been completely integrated with the servo controller and bus coupling in such a small installation space.

The INTAX® linear motor axis is a technology leader. Electronics and software are modular and represents the basis for further developments.

Alois Jenny
Jenny Science AG

Table of contents

1 Mechanics	4
1.1 Driving force / measuring system	4
1.2 Stroke / Weight	4
1.3 Installation dimensions	5
1.4 Mechanical Payload Values	6
1.5 Screwing from the bottom	7
1.6 Screwing from the top	8
1.6.1 Removing the cover on the long side	8
1.6.2 Screws from inside onto base plate	8
2 Accuracy	9
2.1 Positioning	9
2.2 Mechanical accuracy	9
3 Dynamics	9
4 Maintenance, life time	9
4.1 Lubrication	9
4.2 Life time	9
5 Electrics	10
5.1 Installed power	10
5.2 Connector Power / Ethernet	10
6 Safety, Environment	11
6.1 Safety with integrated Servo Controller	11
6.2 Environmental Conditions	11

1 Mechanics



1.1 Driving force / measuring system

INTAX®	Driving Force Fn/FP [N]	Resolution measuring system	Cross section with slide B x H [mm]	Weight slide [g]
Tx yyF08	8 ⁽¹⁾ / 24 ⁽²⁾	1µm abs.	60 x 38	170

(1) Non-stop operation with ambient temperature of 25°C and convection cooling (ambient air)

(2) Single operation (duty cycle 10%)

1.2 Stroke / Weight

Typ	Stroke [mm]	L Installation [mm]	Weight total [g]
Tx 50F08	50	151	425
Tx 100F08	100	201	550
Tx 200F08	200	300	800
Tx 400F08	400	500	1300
Tx 600F08	600	701	1800

1.3 Installation dimensions

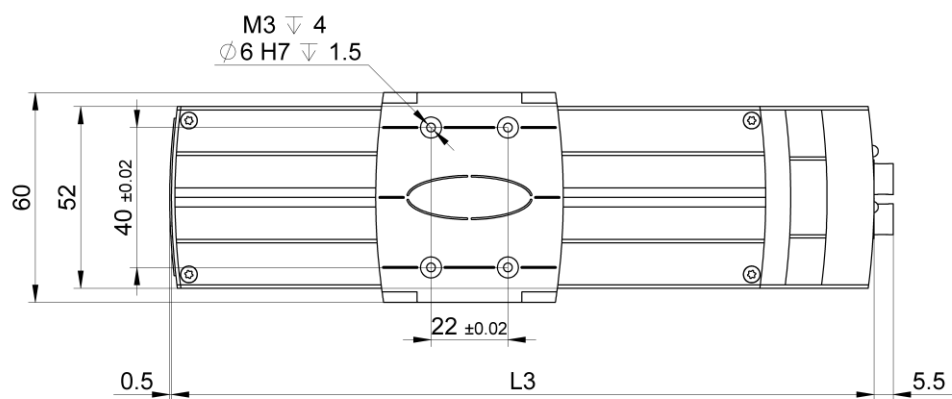
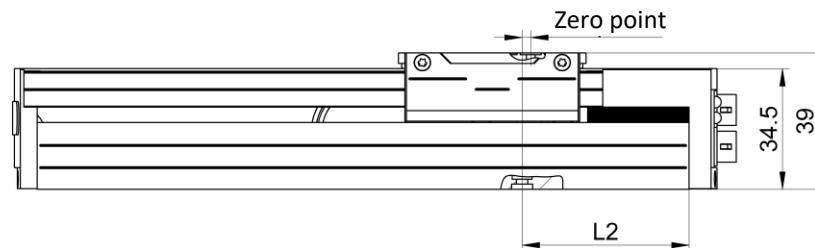
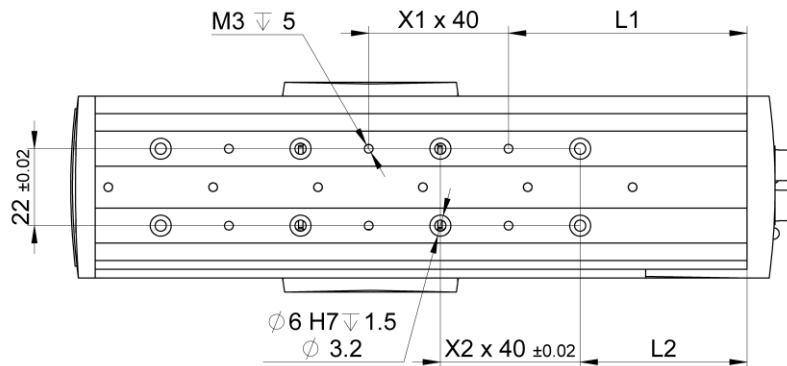

Typ	L1 [mm]	L2 [mm]	L3 [mm]	Nb. X1	Nb. X2	Zero p. [mm]
Tx 50F08	40.5	61.5	149	2	3	16.2
Tx 100F08	68.25	47.75	201	3	3	2.4
Tx 200F08	36.5	56.5	299	6	5	11.2
Tx 400F08	57.25	37.25	500	10	11	-8
Tx 600F08	57.25	37.25	700	15	16	-8

At the end points of the carriage on the left and right, rubber buffers are installed. These are 1mm outside of the maximum stroke.

1.4 Mechanical Payload Values

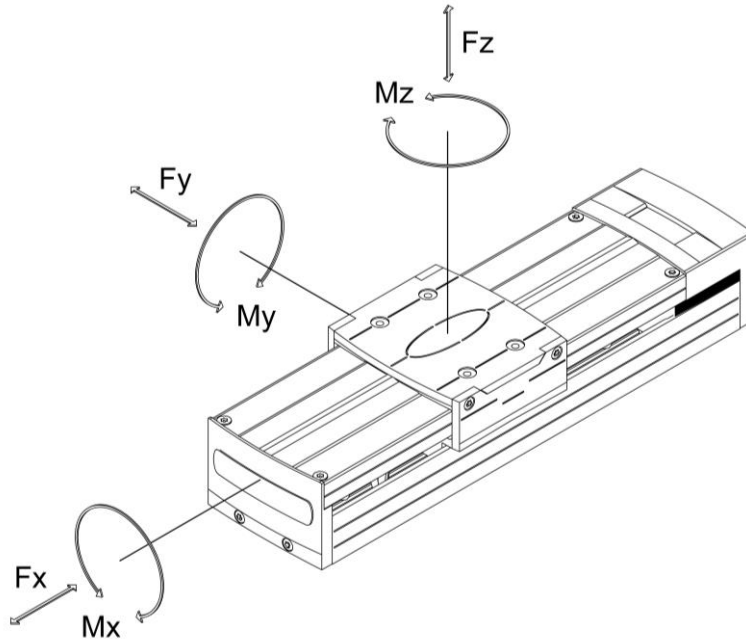

Typ	Fy max [N] Fz max [N]	Mx max [Nm]	My max [Nm] Mz max [Nm]
Tx F08	1370	10	4

If there are multiple forces and moments on the linear motor, besides considering the maximum loads the following equation must comply:

$$\frac{|Fy|}{Fy \max} + \frac{|Fz|}{Fz \max} + \frac{|Mx|}{Mx \max} + \frac{|My|}{My \max} + \frac{|Mz|}{Mz \max} \leq 1$$

1.5 Screwing from the bottom

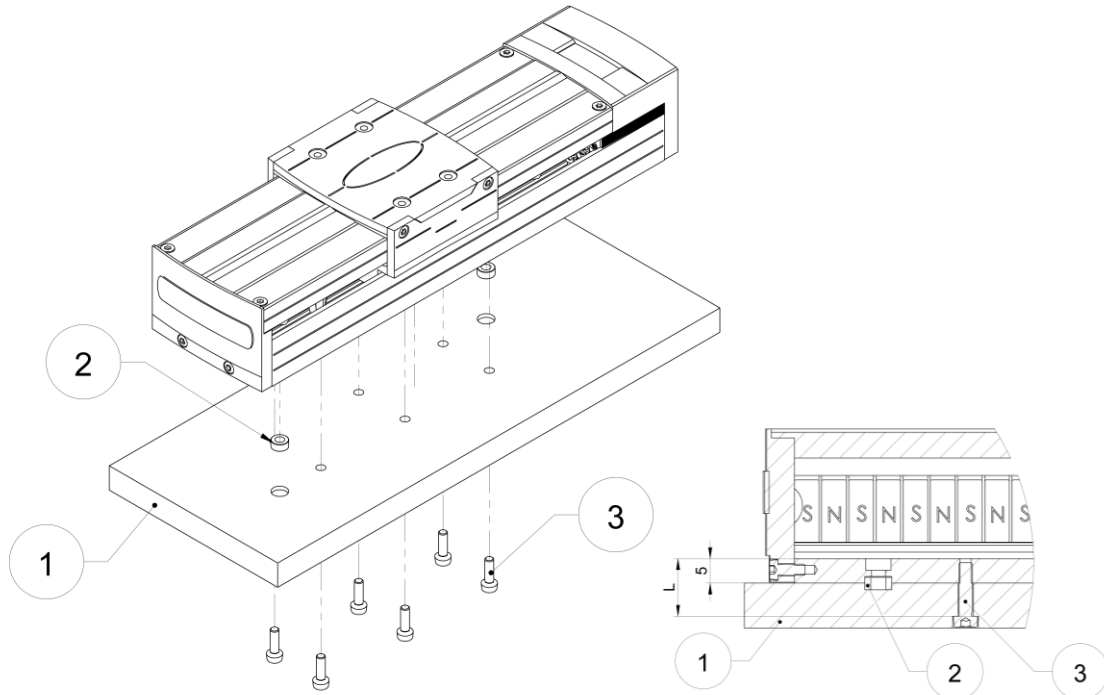

Dowel Pin D6
Outside $\varnothing 6$ H7 / M4 / H2.8

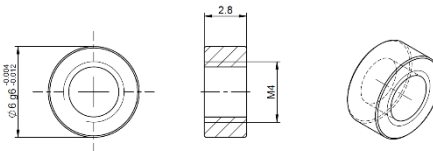

1	Ground plate $\square 10\mu\text{m}$
2	Dowel pin D6
3	Screws M3, Screw in depth max 5mm

1.6 Screwing from the top

1.6.1 Removing the cover on the long side

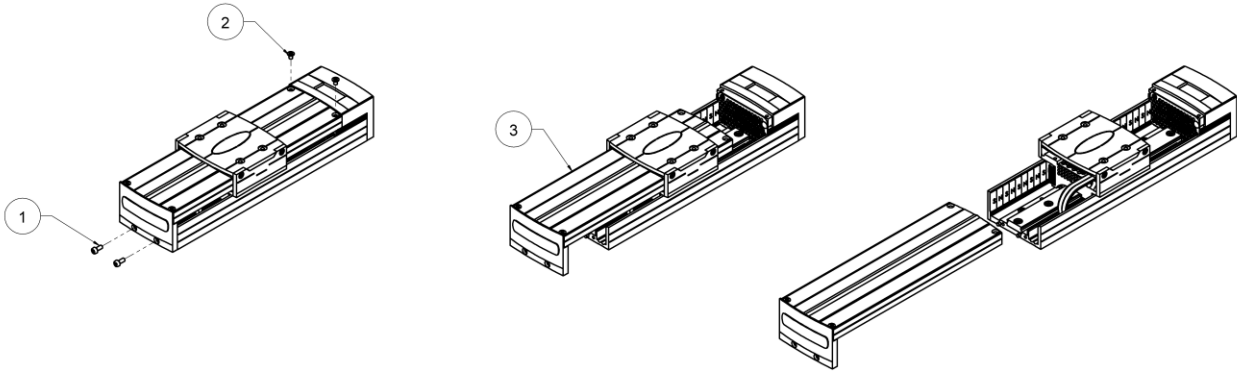

1.6.2 Screws from inside onto base plate

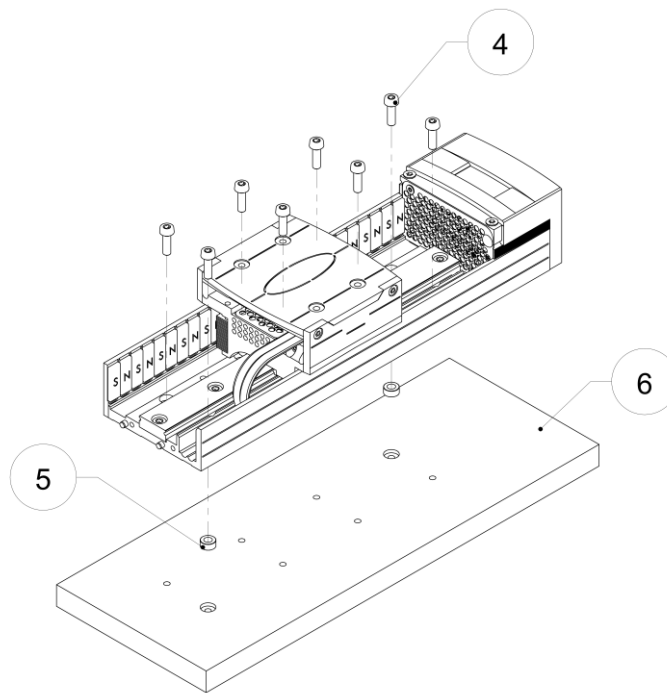

4	Screws M3
5	Dowel pin D6
6	Ground plate $\square 10\mu\text{m}$

Importantly	Screws should not overhang
	Tighten the screws well
	No foreign parts in the motor

2 Accuracy

2.1 Positioning

Distance measuring system	Absolute, without reference travel
Standard resolution	1µm
Accuracy repetitive	± 2µm, bidirectionally
Linear expansion magnetic measuring scale	11µm/m/°C

2.2 Mechanical accuracy

follows later

3 Dynamics

Power supply (12-36VDC)	V DC	12	24	36	
Max. travel speed	m/s	1	2	2	
Load on the carriage	g	100	200	500	1000
Acceleration a_{max}	m/s ²	70	50	30	15

4 Maintenance, life time

4.1 Lubrication

The recirculating ball bearing guide is maintenance-free for 20`000km under normal environment conditions.

4.2 Life time

The INTAX® linear motor axis is a direct drive. This means no mechanical wear and therefore the highest precision over the complete life time.

In general, the recirculating ball bearing guide is the element that determines the life time.

Methods that extend the life time:

- Specify trajectories with curve profile instead of trapezoidal profile (motion profile in the PLC)
- Dynamics always only as high as necessary
- Execute movements more slowly that are not related to the cycle time.
- Avoid dirt particles getting into the guide.

5 Electrics

5.1 Installed power

Power supply (12-36VDC)	V DC	12	24	36
Current Logik	mA	163	88	63
Current Power Fn (I_{stop})	A		1.6	
Current Power Fp (I_{run})	A		4.7	

- (1) Non-stop operation with ambient temperature of 25°C and convection cooling (ambient air)
- (2) Single operation (duty cycle 10%)

5.2 Connector Power / Ethernet

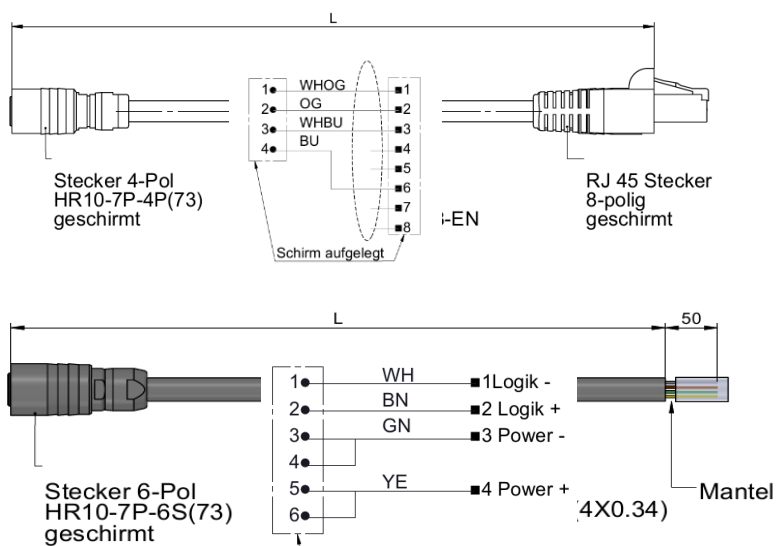
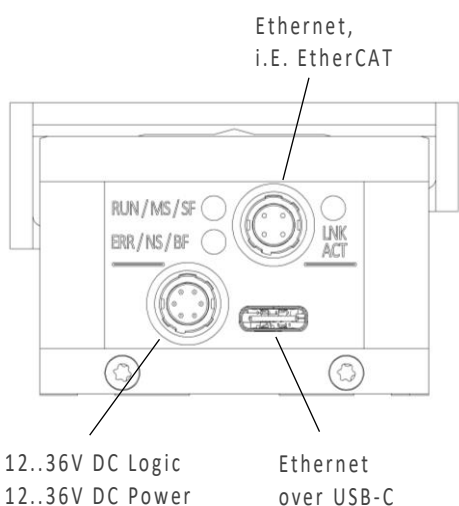

Length L 1,5m standard
x, xm customized
maximal 20m



The required bus protocol has to be specified when ordering and is configured at the factory before delivery.

Functional safety:

STO, realize by switching off DC power, do not interrupt DC logic supply

6 Safety, Environment

6.1 Safety with integrated Servo Controller

<p>EN 61000-6-2:2005 Electromagnetic compatibility (EMC), Immunity for industrial environments</p>	<p>EMC Immunity Testing, Industrial Class A</p>
<p>EN 61326-3-1 IFA:2012 EN 61326-1, EN 61800-3, EN 50370-1</p>	<p>Immunity for Functional Safety Functional safety of power drive systems Electrostatic discharges ESD, Electromagnetic Fields, Fast electric transients Bursts, radio frequency common mode</p>
<p>EN 61000-6-3:2001 Electromagnetic compatibility (EMC), Emission standard for residential, commercial and light-industrial environments</p>	<p>EMC Emissions Testing, Residential Class B</p>
<p>EN 61326-1, EN61800-3, EN50370-1 IFA:2012</p>	<p>Radiated EM Field, Interference voltage Functional safety of power drive systems</p>

6.2 Environmental Conditions

<p>Storage and transport</p>	<p>No outdoor storage. Storage rooms have to be well vented and dry. Storage temperature -25°C up to +55°C (-13°F up to 131°F).</p>
<p>Operational temperature</p>	<p>5°C - 50°C (41°F - 122°F) Environment, reduction in performance at 40°C (104°F).</p>
<p>Operational humidity</p>	<p>10-90% non-condensing.</p>
<p>Cooling</p>	<p>No need of external cooling. If linear motor case is mounted on a heat conductive base, higher performance can be achieved.</p>
<p>Protection category</p>	<p>IP 40</p>

MRL 2006/42/EC notes

- Danger for persons with medical
Implants due to magnetic fields



- Surfaces may become hot, up to 85°C



- Lubrication only with non-toxic lubricants,
verify safety data sheet

- Noise level up to 70 dB(A)

Copyright, Disclaimer

This data sheet contains proprietary information protected
by copyright. All rights are reserved. This document may
not be photocopied, reproduced or translated in whole or
in part without the prior agreement of Jenny Science AG.

Jenny Science AG can neither guarantee nor be made
responsible for any consequences resulting from incorrect
information.

This manual is subject to change without notice.

Jenny Science AG
Sandblatte 11
CH-6026 Rain, Switzerland

Tel +41 (0) 41 255 25 25

www.jennyscience.ch
alois.jenny@jennyscience.ch

© Copyright Jenny Science AG 2022